

4G Battery Camera

Operation Instruction

What's in the box

1. Camera*1
2. Bracket*1
3. Mounting screws kit*1
4. USB charging cable *1
5. Operation instruction*1
6. Solar panel pack(optional)*1
7. SIM card*1
8. Micro SD card(optional)*1

Product appearance

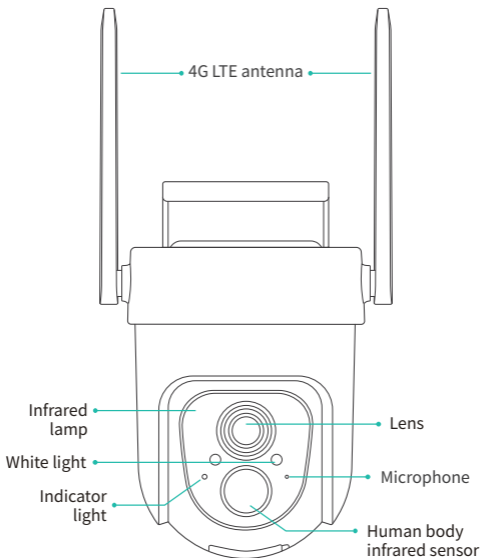

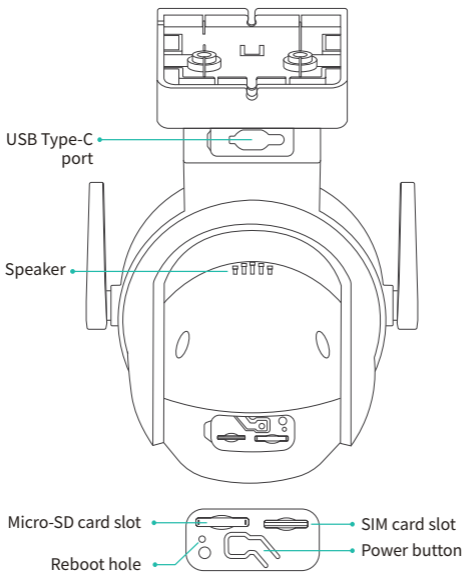

Quick start

Download and install the app

The camera supports Android and iOS apps. For your best experience, please download and install the app with your mobile phone as instructed below, and complete the user registration process in the app.

a) Go to the following link in your system browser to download:

app.vicohome.io

OR

b) Scan the QR code to go to the link to download:



Download app

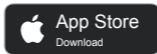

! **DO NOT** use 3rd party QR code scanning tool or app to avoid scam or malware. Use QR code scanning app provided by your mobile phone system, e.g. the system camera app.

Bind the camera

a) Click the "**Add a new device**" button in the app, press and hold the camera power button for 3 seconds to turn on the camera, and the app will automatically search for devices that are on and not bound.

b) Please wait for the indicator light stays blue and the 4G signal strength is strong, which means that the camera recognized the SIM card successfully. Select the device you want to bind in the search results for the next step. The first usage typically requires a slightly longer time for the SIM card and device to establish the initial network connection.



c) After a while, the camera will play a sound indicating that the connection is successful. At this point, please set a name for the camera on the app and select the location where you want to place the camera. Click "**Finish**" to complete the pairing.

Note: Due to the update of the app, the actual steps may be different. Please follow the instructions in the current app.

! Possible problems with binding:

Please check the information on the binding failure page on the app for relevant solutions.

- When you see the "**No SIM card in device**" error, please check if the SIM card is inserted, and available to connect to the internet. Then check if the device is emitting a beeping sound. If silent, double click the power button or restart the device to enter pairing mode and try again.
- When you see the "**SIM card can't connect to internet**" error, please check if the SIM card is inserted, and available to connect to the internet. Then check if the device is emitting a beeping sound. If silent, double click the power button or restart the device to enter pairing mode and try again.
- When you see the "**Weak cellular signal near device**" error, please try to change your device location and try again. Then check if the device is emitting a beeping sound. If silent, double click the power button or restart the device to enter pairing mode and try again.

- When you see the "**Connect device failed**" error, please ensure the app has bluetooth permission enabled. Also check if the device is powered on and emitting a beeping sound and try again.
- When you see the "**Device already connected to VicoHome account**" error, please remove the device from the previous VicoHome account. Then check if the device is emitting a beeping sound. If not, double click the power button or restart the device to enter pairing mode and try again.
- When you see the "**Server connection timeout**", please check whether the device is emitting a beeping sound. If silent, double click the power button or restart the device to enter pairing mode and try again.

Install the camera

It is highly recommended to fully charge the device before the installation process.

1. Select the installation area

Please install the camera in a position where its view is not blocked and ensure that the 4G signal strength is relatively strong.

a) For outdoor use, please install the camera upwards in order to maximize waterproof performance and the PIR motion sensor's efficiency.

! The PIR infrared sensor is more sensitive to movements across the camera's field of view than movements toward or away from the camera.

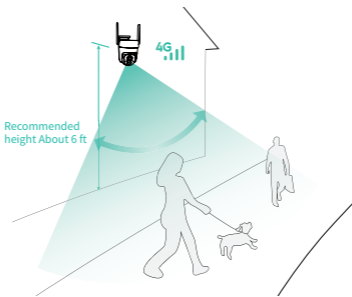

b) When the device is powered by the solar panel, choose an installation location that is not obstructed for better charging efficiency.

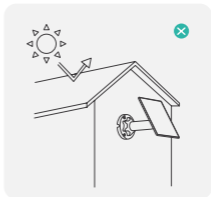
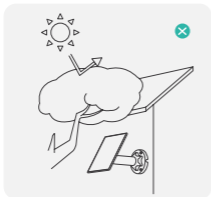
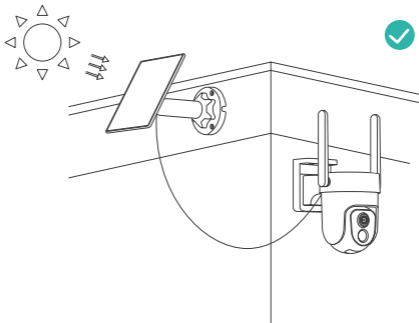

2. Install the bracket

Note: A screwdriver or an electric drill will be needed.

a) Wall

- Use a drill bit to drill holes where the bracket will be placed.
- If your wall is made of concrete, brick, or stucco, hammer the drywall anchors into the wall, then insert the screws. If your wall is made of wood or vinyl, you can omit the anchors and insert the screws.
- Attach the bracket to the wall.

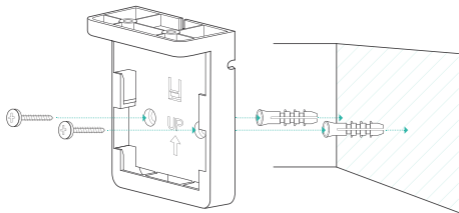

b) Ceiling

- Use a drill bit to drill holes where the bracket will be placed.
- If your wall is made of concrete, brick, or stucco, hammer the drywall anchors into the wall, then insert the screws. If your wall is made of wood or vinyl, you can omit the anchors and insert the screws.
- Attach the bracket to the ceiling.

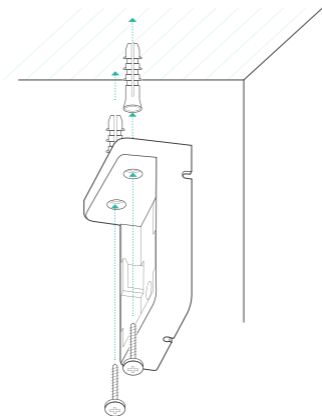

3. Mount the camera

Attach the camera to the installed bracket and push it down to the bottom.

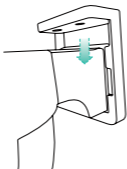

4. Connect the solar panel to the camera (optional)

Open the rubber plug of the camera, then insert the cable of the solar panel to the Type-C USB port of the camera.

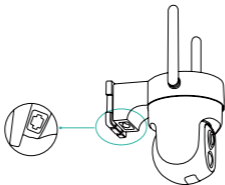

i For solar panel installation methods, please refer to the solar panel manual.

Share the camera

You can use this feature when you need to use the camera with other family members or friends. Only the admin user who has bound the camera for the first time can share and set up the camera, while other members can only view the live video or video playback feature of the camera.

1)For admin user of the camera, find the camera you wish to share on the app homepage or camera settings screen, then click the share button and enter the Share page. Click "**Device Sharing**" to generate a shared QR code.

2)For users who need to be shared with, click "+" on the homepage and select "Add Friend's Device" to enter the scan code page.

3)After the shared user successfully scans the QR code on the admin user's mobile phone, the admin user will receive a confirmation notification, then click "**Accept**" to complete the camera sharing.

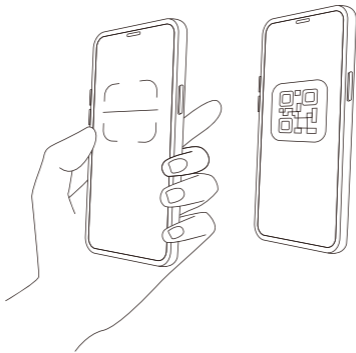

Charge the camera

The App will remind you to charge your camera when the battery is low. Please use the USB Type-C cable to plug into the 5V/1.5A charging adapter to charge the camera. During charging, the camera's indicator light is solid yellow, and when the camera is fully charged, the indicator light will turn into solid green. It will take about 12 hours to fully charge the camera.

Indicator light status

Mode	Status
Working mode	Blue
Sleep mode	Off
Charging mode	Yellow
Fully charged mode	Green

Product specification

Item	Specification
Field of view	127°
Image resolution	Max. 2304×1296
Video bit rate	Adaptive
Storage media	Micro SD card (Up to 128GB)
Rotation Angle	355° pan, 90° tilt
Battery capacity	9000mAh
Adapter requirement	5V/1.5A
Size(without bracket)	5.57×5.08×4.72 (in)

Firmware upgrade

When you connect your camera through the app, it will prompt you if the latest firmware is available. You can also manually check the firmware version in the settings of the App.

- ⓘ Please make sure that your camera is fully charged or connected to the power adapter before upgrading the firmware, please do not cut off the power supply during the upgrading.

FAQ

1.Q: Camera permission management: How to invite family and friends to use my camera together?

A: Open the App and select your camera on the home page. Click the share button on the home page or the "Share" in the camera settings to enter the sharing page, and then click "Invite " to generate a QR code. Your friends can now get some of the access rights by scanning the QR code in your phone.

2.Q: Why can't the camera recognize the SIM card ?

A: Please check if the device has power and is in working condition. Check the installation direction of the SIM card, and make sure the card is inserted properly. If the device is using a third-party SIM card, please check whether the data plan has run out.

3.Q: Will the camera show red lights when night vision is activated?

A: The built-in infrared lamp beads make the camera only show some dim red lights when night vision is activated, but the image quality is still clear under no light environment.

4.Q: Why does the camera frequently disconnect or fail to connect to the network?

A: Please check the 4G signal strength at the camera installation location (you can use the signal strength on the cell phone to assist in judgment) and ensure the SIM card is properly installed.

5.Q: Can the camera connect to Wi-Fi?

A: Wi-Fi is not supported, only the 4G(LTE) network is supported.

6.Q: How to quickly view videos by category?

A: Click the icon in the upper left corner of the "Library" page to start filtering videos by category. Select the category you want to see and then click "Save" to view the video playbacks.

7.Q: What should I do when the device is in malfunction?

A: Long press the power button for 3 seconds to restart it. If there is no response, you can remove the rubber plug at the bottom of the camera. Press the reboot hole with a pointed object to restart the camera.

8.Q: Can I use my own phone SIM card or third-party SIM card?

A: For maximum compatibility and signal strength, it is strongly recommend using the SIM card inserted rather than a third-party SIM card. If you indeed need to use a third-party SIM card, please make sure the SIM card's insert direction is right as the picture shows, and the SIM card is inserted fully into the slot.

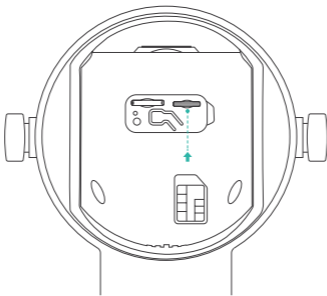

9.Q: Can the SIM card inserted be used on other electronic products?

A: The SIM card inserted in the camera is only compatible with this 4G camera, please do not use it in other electronic products.

Safety

- Do not use the device in extreme temperatures, and never expose the device to strong sunshine or a humid, wet environment.
- The suitable temperature and its accessories is -10°C / 14°F to 45°C / 113°F (The temperature for charging is 0°C / 32°F to 45°C / 113°F).
- The best environment is a temperature range between 5°C / 41°F and 25°C / 77°F .
- When charging, please place the device(s) at room temperature in a place with good ventilation.

Warning

- Replacing the battery with an incorrect version can destroy the safety mechanisms within the device.
- Inappropriate battery disposal, for example, into a fire or a hot oven, or mechanically crushing or cutting the battery, can result in an explosion.
- Leaving a battery in a very high-temperature environment can result in an explosion or the leakage of flammable liquid or gas.
- A battery subjected to extremely low air pressure may result in an explosion or the leakage of flammable liquid or gas.

Attention

- Le remplacement de la batterie par un type incorrect peut détruire les mécanismes de sécurité à l'intérieur de l'appareil.
- L'élimination inappropriée de la batterie — par exemple, dans un feu ou dans un four, ou par écrasement ou coupure— peut provoquer une explosion.
- Le maintien de la batterie dans un environnement à très haute température peut provoquer une explosion ou la fuite de liquide ou de gaz inflammables.
- Une batterie soumise à une pression d'air extrêmement faible peut provoquer une explosion ou la fuite de liquide ou de gaz inflammables.



CAUTION: RISK OF EXPLOSION IF BATTERY IS REPLACED BY AN INCORRECT MODEL. DISPOSES OF USED BATTERIES ACCORDING TO THE INSTRUCTIONS.



ATTENTION: RISQUE D'EXPLOSION SI LA BATTERIE EST REMPLACÉE PAR UN TYPE INCORRECT. ÉLIMINER LES BATTERIES USÉES SELON LES INSTRUCTIONS.

Notice

FCC Statement

This device complies with Part 15 of the FCC Rules. Operation is subject to the following two conditions:

- (1) this device may not cause harmful interference;
- (2) this device must accept any interference received, including interference that may cause undesired operation.

Warning: Changes or modifications not expressly approved by the party responsible for compliance could void the user's authority to operate the equipment.

Note: This equipment has been tested and found to comply with the limits for a Class B digital device, pursuant to Part 15 of the FCC Rules. These limits are designed to provide reasonable protection against harmful interference in a residential installation.

FCC Radio Frequency Exposure Statement

The device has been evaluated to meet general RF exposure requirements. The device can be used in fixed/mobile exposure condition. The min separation distance is 20 cm.



Notice: Shielded cables

This equipment generates,uses and can radiate radio frequency energy and,if not installed and used in accordance with the instructions,may cause harmful interference to radio communications. However,there is no guarantee that interference will not occur in a particular installation.If this equipment does cause harmful interference to radio or television reception, which can be determined by turning the equipment off and on, the user is encouraged to try to correct the interference by one or more of the following measures:

- (1) Reorient or relocate the receiving antenna.
- (2) Increase the separation between the equipment and receiver.
- (3) Connect the equipment into an outlet on a circuit different from that to which the receiver is connected.
- (4) Consult the dealer or an experienced radio/ TV technician for help.

All connections to other computing devices must be made using shielded cables to maintain compliance with FCC regulations.

IC Statement

This device complies with Industry Canada Licence-exempt RSS standard(s). Operation is subject to the following two conditions:

- (1) this device may not cause interference, and
- (2) this device must accept any interference, including interference that may cause undesired operation of the device.

Le présent appareil est conforme aux CNR d'Industrie Canada applicables aux appareils radio exemptés de licence. L'exploitation est soumise aux deux conditions suivantes:

- (1) l'appareil ne doit pas produire de brouillage, et
- (2) l'utilisateur de l'appareil doit accepter tout brouillage radioélectrique subi, même si le brouillage est susceptible d'en compromettre le fonctionnement.

This Class B digital apparatus complies with Canadian ICES-003.

Cet appareil numérique de la classe B est conforme à la norme NMB-003 du Canada.

IC RF Statement

When using the product, maintain a distance of 20cm from the body to ensure compliance with RF exposure requirements.

Lors de l'utilisation du produit, maintenez une distance de 20 cm du corps afin de vous conformer aux exigences en matière d'exposition RF

